

PX 360A High Performance Mig Fume Torch Range

Rating: 300A CO 2 , 270A mixed gas M21, EN60974-7 @ 60% duty cycle.0.9 to 1.2mm wires
Air-Cooled Mig Welding Torch

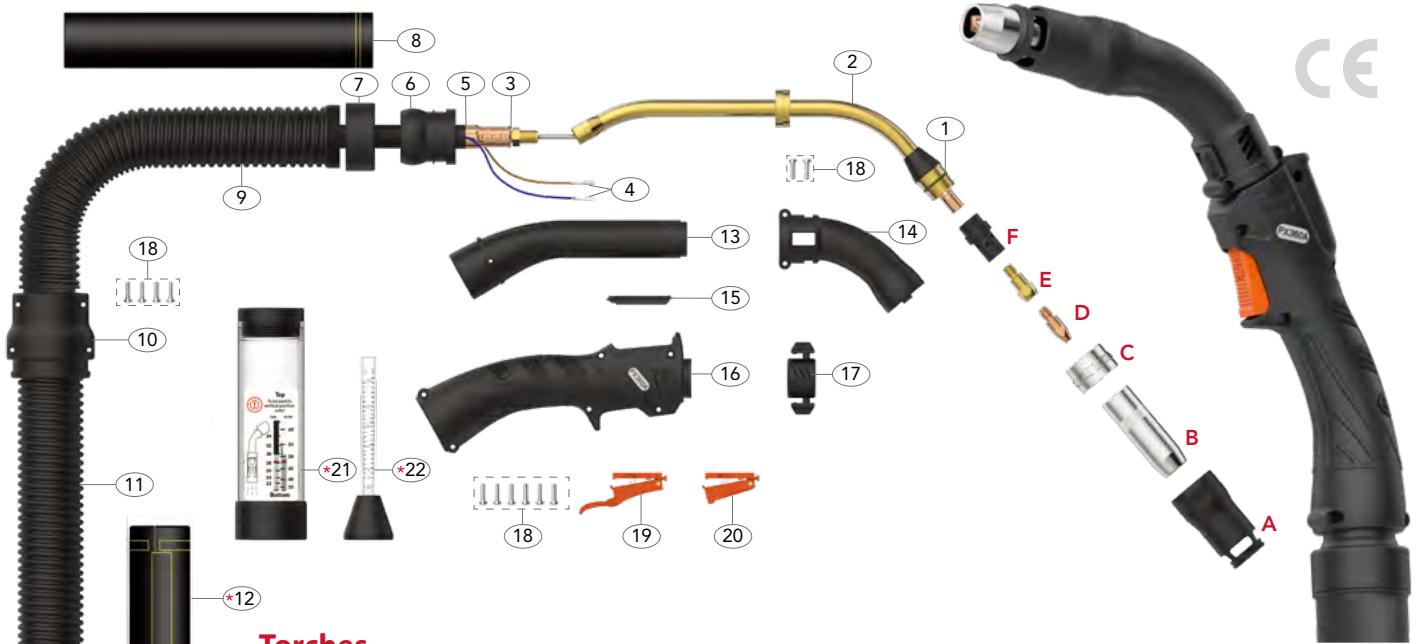

Torches

Description	Part No.		
	3mt	4mt	5mt
Fume Torch c/w Front Leather	PX360A-3M	PX360A-4M	PX360A-5M
Fume Torch c/w Front Leather, Air Flow and Gas Flow Meter	PX360A-3M-FM	PX360A-4M-FM	PX360A-5M-FM
Fume Torch Full Leather	PX360A-3M-LE	PX360A-4M-LE	PX360A-5M-LE
Fume Torch Full Leather c/w Air Flow and Gas Flow Meter	PX360A-3M-LE-FM	PX360A-4M-LE-FM	PX360A-5M-LE-FM

Wear Parts

A Fume Nozzles

Part No.	Description	Bore	Wall	Material
PBX3FN	Fume Nozzle	23.4	1.0mm	Aluminium

B Nozzles

Part No.	Description	Bore	Wall	Material
PBX3TN	Tapered Nozzle	12.0	2.5mm	Copper
*PBX3CN	Conical Nozzle	15.0	2.5mm	Copper
PBX3CYN	Cylindrical Nozzle	18.0	2.5mm	Copper

C Fume Adaptors

Part No.	Description	Material
PBX3002	Fume Nozzle Adaptor	Aluminium

D Contact Tips

Part No.	Description	Material	Wire Size	
			mm	Inch
PB2504-08	Contact Tip	Cu	0.8	0.030"
PB2504-10	Contact Tip	Cu	1.0	0.040"
PB2504-12	Contact Tip	Cu	1.2	0.045"
PB2504-10A	Contact Tip	Cu	1.0	0.040"
PB4014-08	Contact Tip	Cu	0.8	0.030"
PB4014-10	Contact Tip	Cu	1.0	0.040"
*PB4014-12	Contact Tip	Cu	1.2	0.045"

E Tip Adaptors

Part No.	Description	Material
PB3612	Tip Adaptor	Brass
PB3613	Tip Adaptor	Brass
*PB3614	Tip Adaptor	Brass

F Diffusers

Part No.	Description	Colour	Material
PB3605B	Diffuser	Black	DMC3
PB3605C	Diffuser	White	Ceramic
PB3605W	Diffuser	White	DMC3
*PB3605H	Diffuser	Black	HPP

G Liners

Part No.	Description	Length	Wire Size
			mm
*PB2524-30	Steel Liner x 3mt	3.4mt	1.0-1.2
*PB2524-40	Steel Liner x 4mt	4.4mt	1.0-1.2
*PB2524-50	Steel Liner x 5mt	5.4mt	1.0-1.2

Volume Flow Rate

Extractor Nozzle	52 m ³ /h
Connector	65 m ³ /h
Pressure Drop	6.2 kPa
Efficiency	93%
Shielding Gas Flow	16-18 l/min

PX 360A High Performance Mig Fume Torch Range

Rating: 300A CO 2 , 270A mixed gas M21, EN60974-7 @ 60% duty cycle.0.9 to 1.2mm wires

Air-Cooled Mig Welding Torch

Spare Parts

Part No.	Description
1	PBX3-NOR Neck'O'Ring
2	PBX3601 Swan Neck Assembly
3	PB1505 Lock Nut
4	PB1521 Cable Terminal
5	PBX3003-30 Power Cable Assembly x 3mt
	PBX3003-40 Power Cable Assembly x 4mt
	PBX3003-50 Power Cable Assembly x 5mt
6	PBX8015-1 Ball Joint
7	PBX8015-2 Ball Joint Nut
8	PXLC-32 x 1.5M Front Leather Cover 1.5mt
9	PBX5019-1 Front Extract Hose Assembly
10	PBX-HRC32-40 Hose Connector
11	PBX5019-2-30 Rear Extract Hose Assembly x 3mt
	PBX5019-2-40 Rear Extract Hose Assembly x 4mt
	PBX5019-2-50 Rear Extract Hose Assembly x 5mt
13	PBX3-IFC Inner Fume Chamber
14	PBX3-OFC Outer Fume Chamber
15	PB2514-C Handle Control Cover

Part No.	Description
16	PBX2514 Fume Handle Assembly
17	PBX3-AFR Air Flow Regulator
18	AXSP1-1 Screw Pack
19	PBX2516L Microswitch Extended Trigger
20	PBX2516 Microswitch Standard Trigger

Optional

*12	PXLC-40 x 0.75M	Rear Leather Cover 0.75mt
	PXLC-40 x 1.75M	Rear Leather Cover 1.75mt
	PXLC-40 x 2.75M	Rear Leather Cover 2.75mt
*21	PBX3-AFM	Air Flow Meter
*22	PBX-GFM	Gas Flow Meter